

UltraFlow4P

UltraFlow from IMI Cornelius provides the ultimate solution for busy events and stadiums. The four-product UltraFlow system allows simultaneous operation of four dispense heads with a dispense cycle of 15 seconds. Using intelligent technology and single lever operation, the system provides highly accurate portioning, aiding stock control and guaranteeing the consumer a precisely fixed measure of beer.

The UltraFlow system consistently delivers superior quality and consistency of in-glass temperatures, it also increases a bar's productivity, reducing queues, increasing repeat purchase and increasing revenue.

The UltraFlow system offers a wide range of unique benefits:

- Superior quality and consistency of in-glass dispense
- Reduced congestion enhancing customer satisfaction
- Less bar staff and dispense points on the bar
- Reduced skill levels required by staff due to the easy-to-use electronically controlled system
- More sales in a limited space of time
- Reduced wastage providing greater keg yield
- Left or Right Hand operation
- UK Weights & Measures approved
- Unique tray system, speeding up distribution of dispensed products



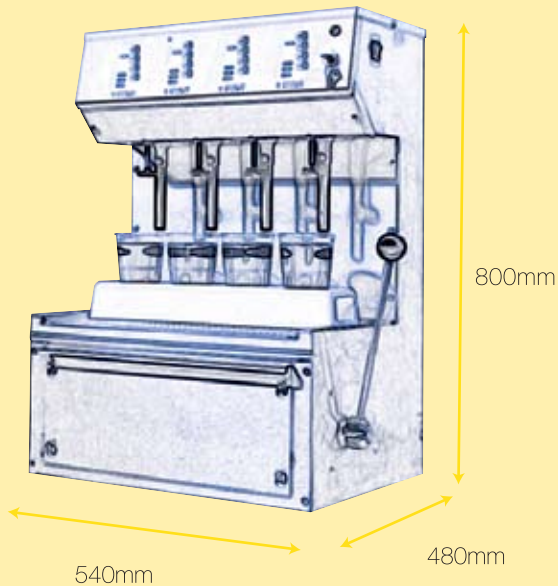

Standard Features:

Pre determined product dispense volume: single pint
 Auto detect empty keg/CO₂ bottle
 1 Pint stroke completion

Performance:

Dispense rate 1x4p: 6-9 secs
 Maximum Ambient Temperature: 35°C

Finish:

Stainless Steel

Electrical Supply:

24v, site unit no more than 1.5 metres away from the mains power supply

Cooling:

Cornelius offers a comprehensive range of cooling options to match the fast dispense speed of UltraFlow to maintain a perfectly chilled product.

Fixing:

Four screws secure the 4p UltraFlow on four corners through the bar or bolt onto free standing cabinet

Additional Information:

Product Inlet:	3/8" JG push in
Water Circulation:	3/8" JG push in
Weight:	47kg
Drain pipe situated beneath the drip tray	

Please note that the UltraFlow font is part of a system. Purchasing the font alone will not allow fast dispense unless installed along with other essential equipment.

Compliance to standards and legislation
 The UltraFlow dispense head complies with UK legislation. Materials coming into contact with the product are of "Food Grade" quality and are compatible with common beer line cleaning fluids.

IMI Cornelius reserves the right to modify the details in the publication as products and specifications are updated and improved.

